

SIZES	F/F	ØP	C	H OPEN	H CLOSE	ØWH
15 mm	73	9.5	14	159	143	86
20 mm	80	12.7	16	162	146	86
25 mm	100	17.5	20	191	171	116
32 mm	145	23.8	20	228	199	150
40 mm	145	28.6	24	228	199	150
50 mm	160	36.5	26	265	236	150

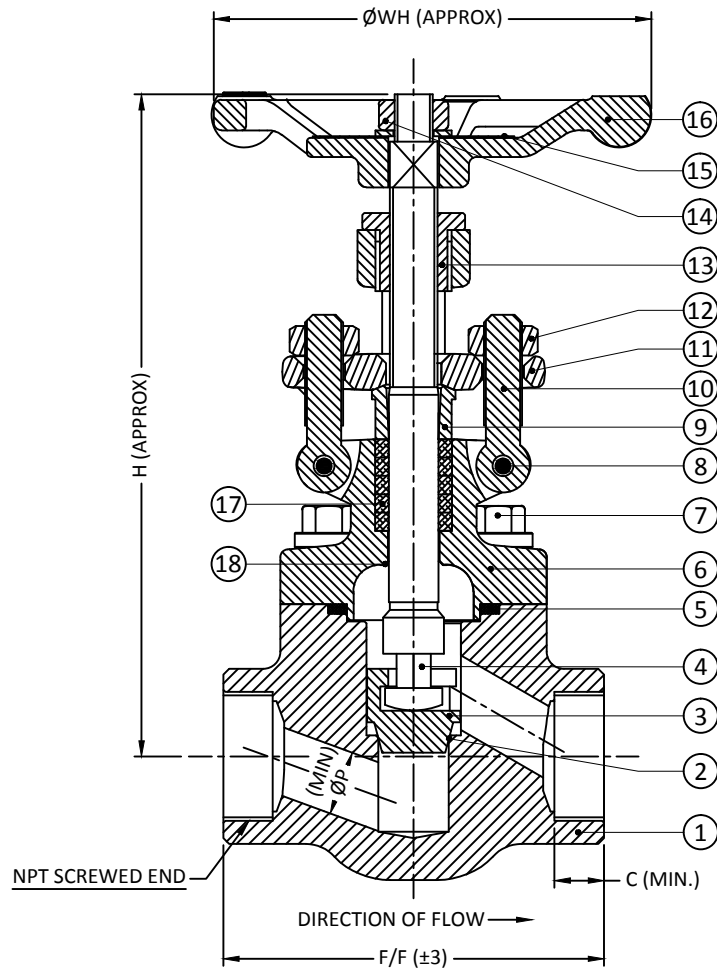

- DESIGN STANDARD :- ISO 15761.
- TESTING STANDARD :- API 598.
- FACE TO FACE STANDARD :- MANUFACTURER'S STANDARD.
- SCREWED END STANDARD :- ASME B1.20.1.

HYDRO TEST PRESSURE

SHELL/BODY	211 kg / cm ²	15 SEC.
SEAT	153 kg / cm ²	15 SEC.
BACK SEAT	153 kg / cm ²	15 SEC.

PNEUMATIC TEST PRESSURE

SEAT	7 kg / cm ²	15 SEC.
------	------------------------	---------

- To be used for client approval / remarks where applicable.



Custom Steam Solutions Inc

Your Steam System Integrators

18	BACK SEAT	INTEGRAL	-
17	GLAND PACKING	FLEXIBLE GRAPHITE RINGS	5
16	HAND WHEEL	MI / SGIRON	1
15	NAME PLATE	STAINLESS STEEL	1
14	STEM NUT	ASTM A 194 GR. 2H	1
13	YOKE SLEEVE	ASTM A 582 GR. SS-416	1
12	EYE BOLT NUT	ASTM A 194 GR. 2H	2
11	GLAND FLANGE	ASTM A 105	1
10	EYE BOLT	ASTM A 193 GR. B7	2
9	GLAND BUSH	ASTM A 276 TYPE SS-410	1
8	EYE BOLT PIN	ASTM A 276 TYPE SS-410	2
7	HEX BOLT	ASTM A 193 GR. B7	4
6	BONNET	ASTM A 105	1
5	GASKET	SS-316 SPIRAL WOUNDED+GRAPHITE	1
4	STEM	ASTM A 182 GR. F6a	1
3	PLUG	ASTM A 217 GR. CA-15	1
2	SEAT RING	13% CR. INTEGRAL	-
1	BODY	ASTM A 105	1

NO.	DESCRIPTION	MATERIAL	QTY.
All dimensions are in mm			APP. DATE
Scale :- Not to scale			MITTAL 07-11-19
TITLE :- GLOBE VALVE - 800# - A105 - NPT		CHK. DATE	NIKUL 07-11-19
DRG. NO. :- GMV-GBV-01		DRN. DATE	BHAVIN 07-11-19

C				PROJECT :-
B				CUSTOMER :- CUSTOMIZED STEAM SOLUTIONS PVT LTD
A				INQUIRY NO. :-
REV.	DESCRIPTION	DATE	APP. BY	P.O.NO. :-
				DATE :-



G M VALVE PVT. LTD. (RAJKOT)

SIZES	F/F	ØP	C	H OPEN	H CLOSE	ØWH
15 mm	73	9.5	14	159	143	86
20 mm	80	12.7	16	162	146	86
25 mm	100	17.5	20	191	171	116
32 mm	145	23.8	20	228	199	150
40 mm	145	28.6	24	228	199	150
50 mm	160	36.5	26	265	236	150

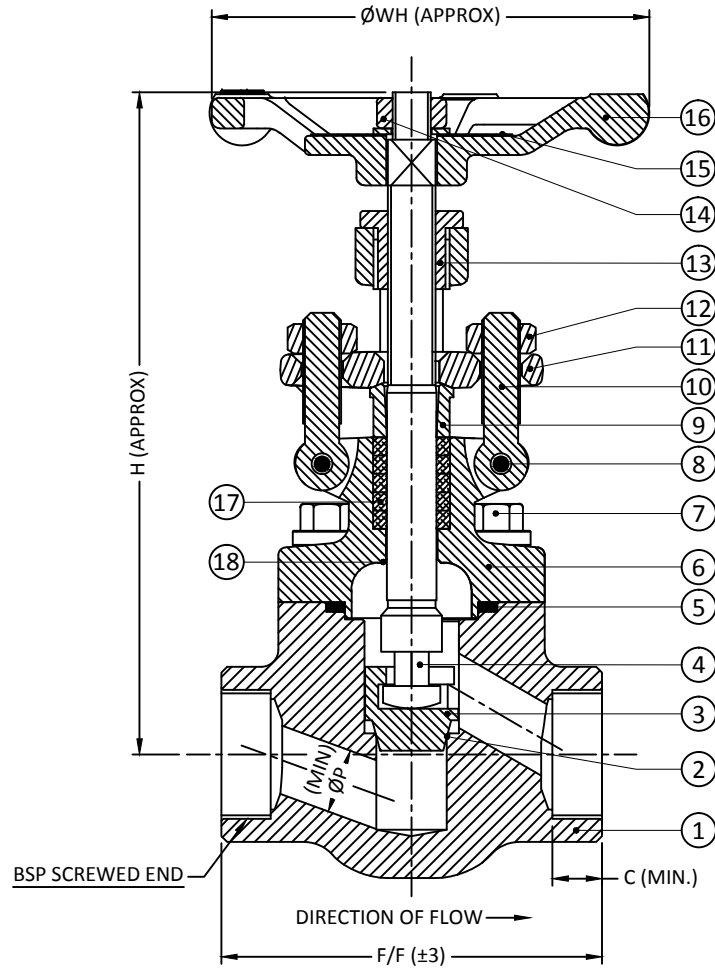

- DESIGN STANDARD :- ISO 15761.
- TESTING STANDARD :- API 598.
- FACE TO FACE STANDARD :- MANUFACTURER'S STANDARD.
- SCREWED END STANDARD :- ASME B1.20.1.

HYDRO TEST PRESSURE

SHELL/BODY	211 kg / cm ²	15 SEC.
SEAT	153 kg / cm ²	15 SEC.
BACK SEAT	153 kg / cm ²	15 SEC.

PNEUMATIC TEST PRESSURE

SEAT	7 kg / cm ²	15 SEC.
------	------------------------	---------

- To be used for client approval / remarks where applicable.

18	BACK SEAT	INTEGRAL	-
17	GLAND PACKING	FLEXIBLE GRAPHITE RINGS	5
16	HAND WHEEL	MI / SGIRON	1
15	NAME PLATE	STAINLESS STEEL	1
14	STEM NUT	ASTM A 194 GR. 2H	1
13	YOKE SLEEVE	ASTM A 582 GR. SS-416	1
12	EYE BOLT NUT	ASTM A 194 GR. 2H	2
11	GLAND FLANGE	ASTM A 105	1
10	EYE BOLT	ASTM A 193 GR. B7	2
9	GLAND BUSH	ASTM A 276 TYPE SS-410	1
8	EYE BOLT PIN	ASTM A 276 TYPE SS-410	2
7	HEX BOLT	ASTM A 193 GR. B7	4
6	BONNET	ASTM A 105	1
5	GASKET	SS-316 SPIRAL WOUNDED+GRAPHITE	1
4	STEM	ASTM A 182 GR. F6a	1
3	PLUG	ASTM A 217 GR. CA-15	1
2	SEAT RING	13% CR. INTEGRAL	-
1	BODY	ASTM A 105	1

NO.	DESCRIPTION	MATERIAL	QTY.
All dimensions are in mm			APP. DATE
Scale :- Not to scale			MITTAL 07-11-19
TITLE :- GLOBE VALVE - 800# - A105 - BSP		CHK. DATE	NIKUL 07-11-19
DRG. NO. :- GMV-GBV-02		DRN. DATE	BHAVIN 07-11-19

C				PROJECT :-
B				CUSTOMER :- CUSTOMIZED STEAM SOLUTIONS PVT LTD
A				INQUIRY NO. :-
REV.	DESCRIPTION	DATE	APP. BY	P.O.NO. :-
				DATE :-



G M VALVE PVT. LTD. (RAJKOT)

SIZES	F/F	ØP	C	H OPEN	H CLOSE	ØWH
15 mm	73	9.5	14	151	135	86
20 mm	80	12.7	16	157	137	86
25 mm	100	17.5	20	186	162	116
32 mm	120	23.8	20	237	201	150
40 mm	120	28.6	24	237	201	150
50 mm	130	36.5	26	268	223	150

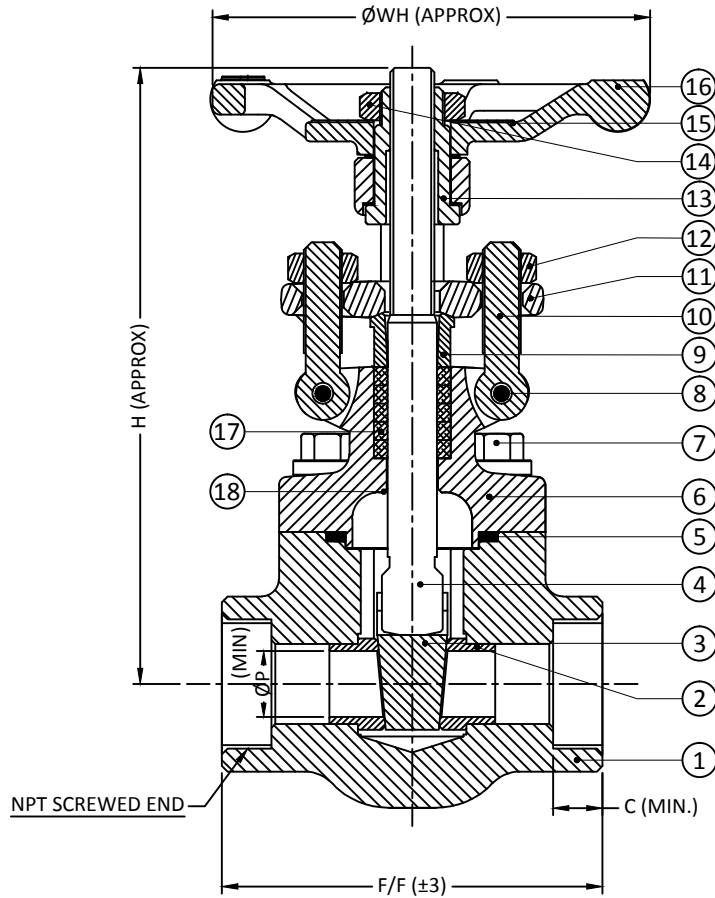

- DESIGN STANDARD :- API 602 / ISO 15761.
- TESTING STANDARD :- API 598.
- FACE TO FACE STANDARD :- MANUFACTURER'S STANDARD.
- SCREWED END STANDARD :- ASME B1.20.1.

HYDRO TEST PRESSURE

SHELL/BODY	211 kg / cm ²	15 SEC.
SEAT	153 kg / cm ²	15 SEC.
BACK SEAT	153 kg / cm ²	15 SEC.

PNEUMATIC TEST PRESSURE

SEAT	7 kg / cm ²	15 SEC.
------	------------------------	---------

- To be used for client approval / remarks where applicable.

18	BACK SEAT	INTEGRAL	-
17	GLAND PACKING	FLEXIBLE GRAPHITE RINGS	5
16	HAND WHEEL	MI / SGIRON	1
15	NAME PLATE	STAINLESS STEEL	1
14	STEM NUT	ASTM A 194 GR. 2H	1
13	YOKE SLEEVE	ASTM A 582 GR. SS-416	1
12	EYE BOLT NUT	ASTM A 194 GR. 2H	2
11	GLAND FLANGE	ASTM A 105	1
10	EYE BOLT	ASTM A 193 GR. B7	2
9	GLAND BUSH	ASTM A 276 TYPE SS-410	1
8	EYE BOLT PIN	ASTM A 276 TYPE SS-410	2
7	HEX BOLT	ASTM A 193 GR. B7	4
6	BONNET	ASTM A 105	1
5	GASKET	SS-316 SPIRAL WOUNDED+GRAPHITE	1
4	STEM	ASTM A 182 GR. F6a	1
3	WEDGE	ASTM A 217 GR. CA-15	1
2	SEAT RING	ASTM A 276 TYPE SS-410	2
1	BODY	ASTM A 105	1

NO.	DESCRIPTION	MATERIAL	QTY.
All dimensions are in mm			APP. DATE
Scale :- Not to scale			MITTAL 07-11-19
TITLE :- GATE VALVE - 800# - A105 - NPT		CHK. DATE	NIKUL 07-11-19
DRG. NO. :- GMV-GTV-03		DRN. DATE	BHAVIN 07-11-19

C				PROJECT :-
B				CUSTOMER :- CUSTOMIZED STEAM SOLUTIONS PVT LTD
A				INQUIRY NO. :-
REV.	DESCRIPTION	DATE	APP. BY	P.O.NO. :-
				DATE :-



G M VALVE PVT. LTD. (RAJKOT)

SIZES	F/F	ØP	C	H OPEN	H CLOSE	ØWH
15 mm	73	9.5	14	151	135	86
20 mm	80	12.7	16	157	137	86
25 mm	100	17.5	20	186	162	116
32 mm	120	23.8	20	237	201	150
40 mm	120	28.6	24	237	201	150
50 mm	130	36.5	26	268	223	150

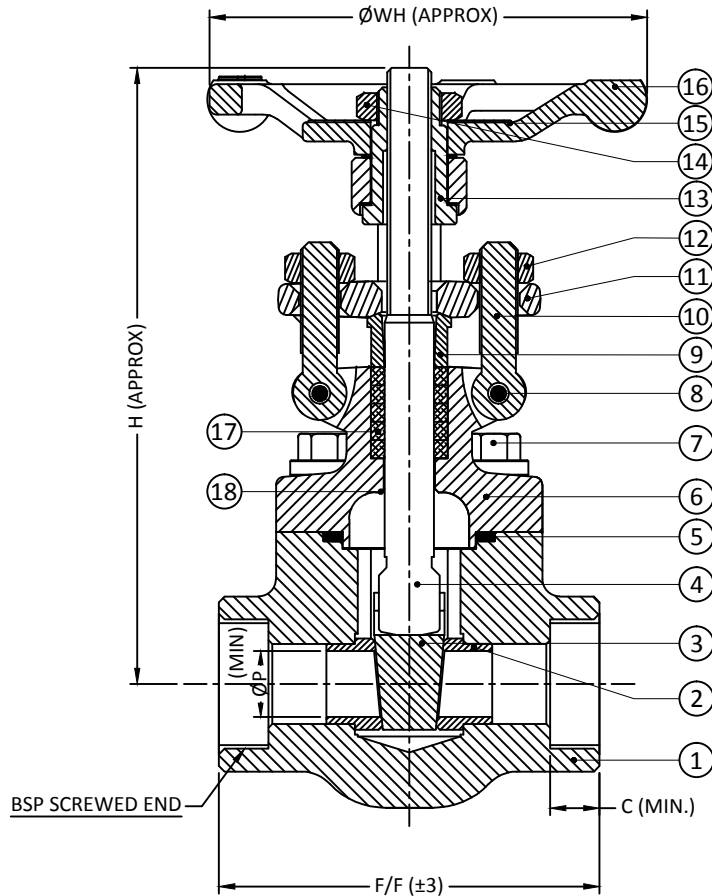

- DESIGN STANDARD :- API 602 / ISO 15761.
- TESTING STANDARD :- API 598.
- FACE TO FACE STANDARD :- MANUFACTURER'S STANDARD.
- SCREWED END STANDARD :- ASME B1.20.1.

HYDRO TEST PRESSURE

SHELL/BODY	211 kg / cm ²	15 SEC.
SEAT	153 kg / cm ²	15 SEC.
BACK SEAT	153 kg / cm ²	15 SEC.

PNEUMATIC TEST PRESSURE

SEAT	7 kg / cm ²	15 SEC.
------	------------------------	---------

- To be used for client approval / remarks where applicable.

18	BACK SEAT	INTEGRAL	-
17	GLAND PACKING	FLEXIBLE GRAPHITE RINGS	5
16	HAND WHEEL	MI / SGIRON	1
15	NAME PLATE	STAINLESS STEEL	1
14	STEM NUT	ASTM A 194 GR. 2H	1
13	YOKE SLEEVE	ASTM A 582 GR. SS-416	1
12	EYE BOLT NUT	ASTM A 194 GR. 2H	2
11	GLAND FLANGE	ASTM A 105	1
10	EYE BOLT	ASTM A 193 GR. B7	2
9	GLAND BUSH	ASTM A 276 TYPE SS-410	1
8	EYE BOLT PIN	ASTM A 276 TYPE SS-410	2
7	HEX BOLT	ASTM A 193 GR. B7	4
6	BONNET	ASTM A 105	1
5	GASKET	SS-316 SPIRAL WOUNDED+GRAPHITE	1
4	STEM	ASTM A 182 GR. F6a	1
3	WEDGE	ASTM A 217 GR. CA-15	1
2	SEAT RING	ASTM A 276 TYPE SS-410	2
1	BODY	ASTM A 105	1

NO.	DESCRIPTION	MATERIAL	QTY.
All dimensions are in mm			APP. DATE
Scale :- Not to scale			MITTAL 07-11-19
TITLE :- GATE VALVE - 800# - A105 - BSP		CHK. DATE	NIKUL 07-11-19
DRG. NO. :- GMV-GTV-04		DRN. DATE	BHAVIN 07-11-19

C				PROJECT :-
B				CUSTOMER :- CUSTOMIZED STEAM SOLUTIONS PVT LTD
A				INQUIRY NO. :-
REV.	DESCRIPTION	DATE	APP. BY	P.O.NO. :-
				DATE :-



G M VALVE PVT. LTD. (RAJKOT)

VALVE SIZE	F/F	øP	C	L	H
15 mm	68	10.0	16	128	38
20 mm	73	14.0	16	128	40
25 mm	96	20.0	22	155	53
32 mm	103	25.0	22	165	56
40 mm	116	30.5	24	202	75
50 mm	128	37.3	27	202	80

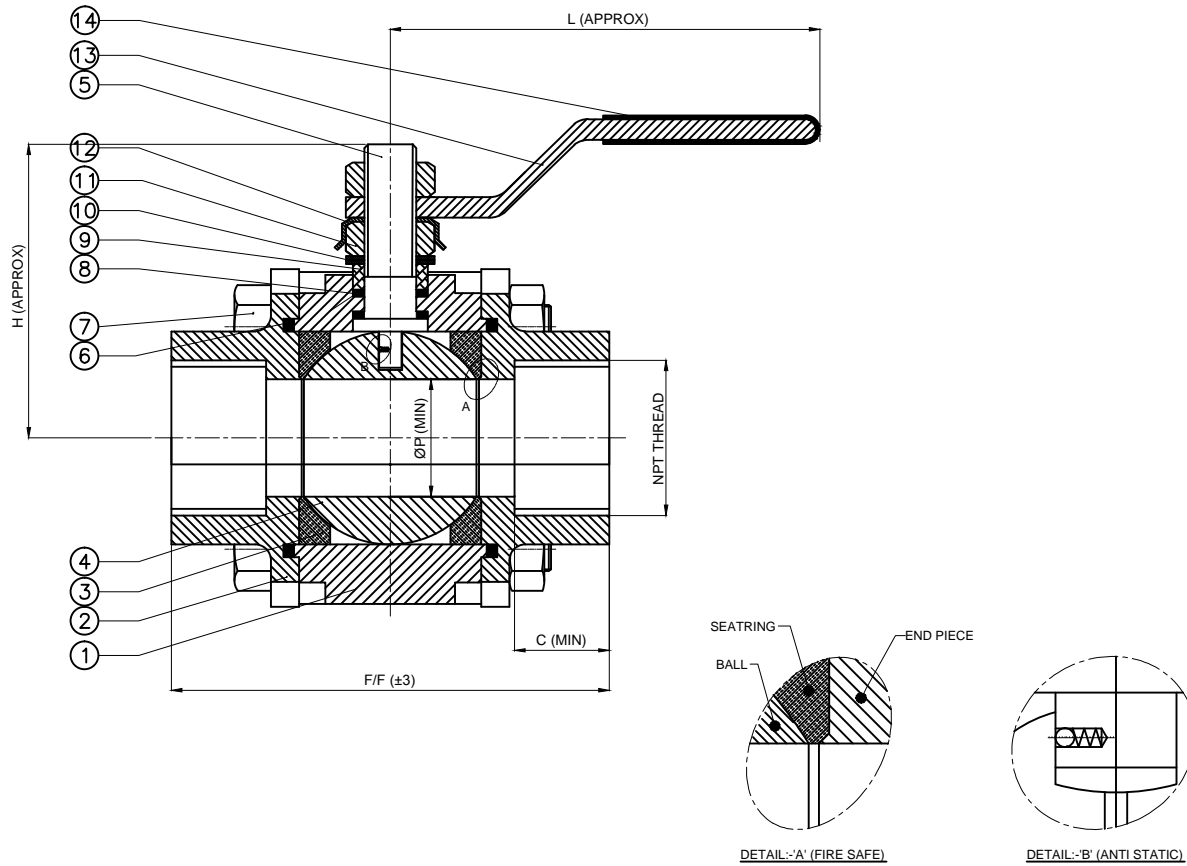

SPECIFICATION-
VALVE RATING – 800#
DESIGN STD. – ISO 17292
TESTING STD.- API 607
F TO F AS PER MFG. STANDARD

HYDRO TEST PRESSURE		
SHELL/BODY	211 Kg/Cm ²	15 SEC.
SEAT	69 Kg/Cm ²	15 SEC.
PNEUMATIC TEST PRESSURE		
SEAT	7 Kg/Cm ²	15 SEC.

NO.	DESCRIPTION	MATERIAL	QTY.
14	SLEEVE	PVC	1
13	HANDLE	CARBON STEEL	1
12	LOCKING	MS	1
11	STEM NUT	ASTM A 194 GR. 2H	2
10	DISH WASHER	SPRING STEEL	2
09	GLAND BUSH	ASTM A 276 TYPE SS-304	1
08	GLAND PACKING	GRAFOIL	2
07	HEX. BOLTS & NUTS	ASTM A 193 GR. B7 / 2H	4
06	O RING	GRAFOIL	2
05	STEM	ASTM A 276 TYPE SS-304	1
04	BALL	ASTM A 351 GR. CF8	1
03	SEAT RING	CARBON FILLED TEFLON	2
02	SIDE PIECE	ASTM A 105	2
01	BODY	ASTM A 105	1

TQ. NO.-XXXX		APPD.	MITTAL
IV NO.- XXXX		DT.	07/11/19
TITLE :-BALL VALVE RB 800# FS A105 S/E NPT		CHKD.	NIKUL
		DT.	07/11/19
DRG.NO. :- GMV-BLV-05		DRN.	BHAVIN
		DT.	07/11/19

1. ALL DIMENSIONS ARE IN MM.				PROJECT: - - - - -	
B	-	XX	XX	MEDIA: - - - - -	
A	-	XXX	XX	CUSTOMER: - CUSTOMIZED STEAM SOLUTIONS PVT LTD	
REV.	MOD.NO.	DATE	SIGN	IF IN DOUBT. ASK...	SCALE N.T.S. ENQUIRY NO.: -XXXXXXXXXX



VALVE SIZE	F/F	øP	C	L	H
15 mm	68	10.0	16	128	38
20 mm	73	14.0	16	128	40
25 mm	96	20.0	22	155	53
32 mm	103	25.0	22	165	56
40 mm	116	30.5	24	202	75
50 mm	128	37.3	27	202	80

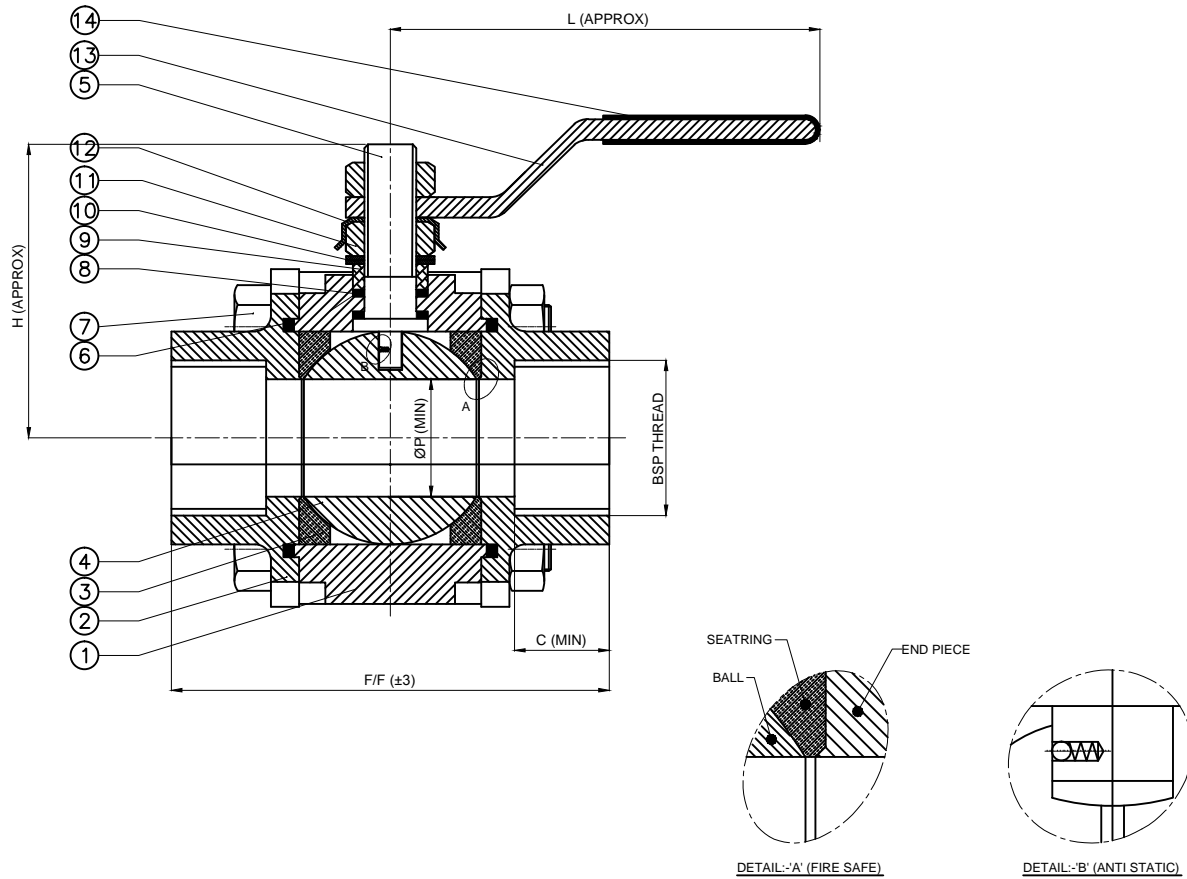

SPECIFICATION-
VALVE RATING - 800#
DESIGN STD. - ISO 17292
TESTING STD.- API 607
F TO F AS PER MFG. STANDARD

HYDRO TEST PRESSURE		
SHELL/BODY	211 Kg/Cm ²	15 SEC.
SEAT	69 Kg/Cm ²	15 SEC.
PNEUMATIC TEST PRESSURE		
SEAT	7 Kg/Cm ²	15 SEC.

14	SLEEVE	PVC	1
13	HANDLE	CARBON STEEL	1
12	LOCKING	MS	1
11	STEM NUT	ASTM A 194 GR. 2H	2
10	DISH WASHER	SPRING STEEL	2
09	GLAND BUSH	ASTM A 276 TYPE SS-304	1
08	GLAND PACKING	GRAFOIL	2
07	HEX. BOLTS & NUTS	ASTM A 193 GR. B7 / 2H	4
06	O RING	GRAFOIL	2
05	STEM	ASTM A 276 TYPE SS-304	1
04	BALL	ASTM A 351 GR. CF8	1
03	SEAT RING	CARBON FILLED TEFLON	2
02	SIDE PIECE	ASTM A 105	2
01	BODY	ASTM A 105	1
NO.	DESCRIPTION	MATERIAL	QTY.

TQ. NO.-XXXX		APPD.	MITTAL
IV NO.- XXXX		DT.	07/11/19
TITLE :-BALL VALVE RB 800# FS A105 S/E BSP		CHKD.	NIKUL
DRG.NO. :- GMV-BLV-06		DT.	07/11/19
		DRN.	BHAVIN
		DT.	07/11/19

1. ALL DIMENSIONS ARE IN MM.				PROJECT: - - - - -
B	-	XX	XX	MEDIA: - - - - -
A	-	XXX	XX	CUSTOMER: - CUSTOMIZED STEAM SOLUTIONS PVT LTD
REV.	MOD.NO.	DATE	SIGN	ENQUIRY NO.: -XXXXXXXXXX
			IF IN DOUBT. ASK...	SCALE N.T.S.



SIZES	F/F	ØP	C	H OPEN	H CLOSE	ØWH
15 mm	110	9	14	127	104	86
20 mm	112	12	13	127	104	86
25 mm	126	17	20	175	141	116

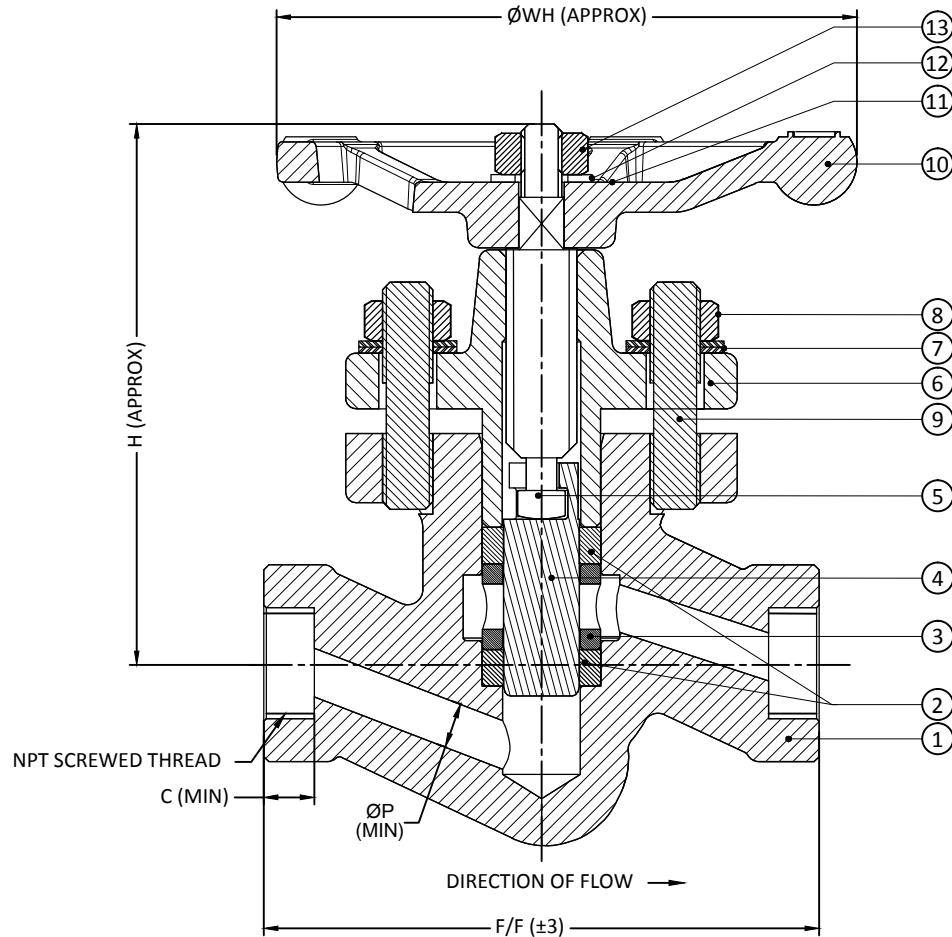

- DESIGN STANDARD :- API 602.
- TESTING STANDARD :- API 598.
- FACE TO FACE STANDARD :- MANUFACTURER'S STANDARD.
- SCREWED END STANDARD :- ASME B1.20.1

HYDRO TEST PRESSURE		
SHELL/BODY	211 kg / cm ²	15 SEC.
PNEUMATIC TEST PRESSURE		
LEAK TEST	7 kg / cm ²	15 SEC.

● To be used for client approval / remarks where applicable.

13	STEM NUT	ASTM A 194 GR. 2H	1
12	HANDWHEEL WASHER	MS	1
11	NAME PLATE	STAINLESS STEEL	1
10	HAND WHEEL	MI / SGIRON	1
9	STUD	ASTM A 193 GR. B7	2/4
8	NUT	ASTM A 194 GR. 2H	2/4
7	BELLEVILLE WASHER	50CR V4/ASTM240 Gr.302	4/8
6	BONNET	ASTM A 105	1
5	SPINDLE	ASTM A 276 TYPE SS 410	1
4	PISTON	ASTM A 217 GR. CA15	1
3	LANTERN BUSH	ASTM A 276 TYPE SS 410	1
2	SEALING RING	GRAPHITE WITH SS304 REINFORCED	2
1	BODY	ASTM A 105	1

NO.	DESCRIPTION	MATERIAL	QTY.
All dimensions are in mm			APP. DATE
Scale :- Not to scale			MITTAL 07-11-19
TITLE :- PISTON VALVE - 800# - A105 - NPT		CHK. DATE	NIKUL 07-11-19
DRG. NO. :- GMV-PV-07		DRN. DATE	BHAVIN 07-11-19

C				PROJECT :-	
B				CUSTOMER :- CUSTOMIZED STEAM SOLUTIONS PVT LTD	
A				INQUIRY NO. :-	
REV.	DESCRIPTION	DATE	APP. BY	P.O.NO. :-	DATE :-



G M VALVE PVT. LTD. (RAJKOT)

SIZES	F/F	ØP	C	H OPEN	H CLOSE	ØWH
40 mm	180	28	24	231	185	150

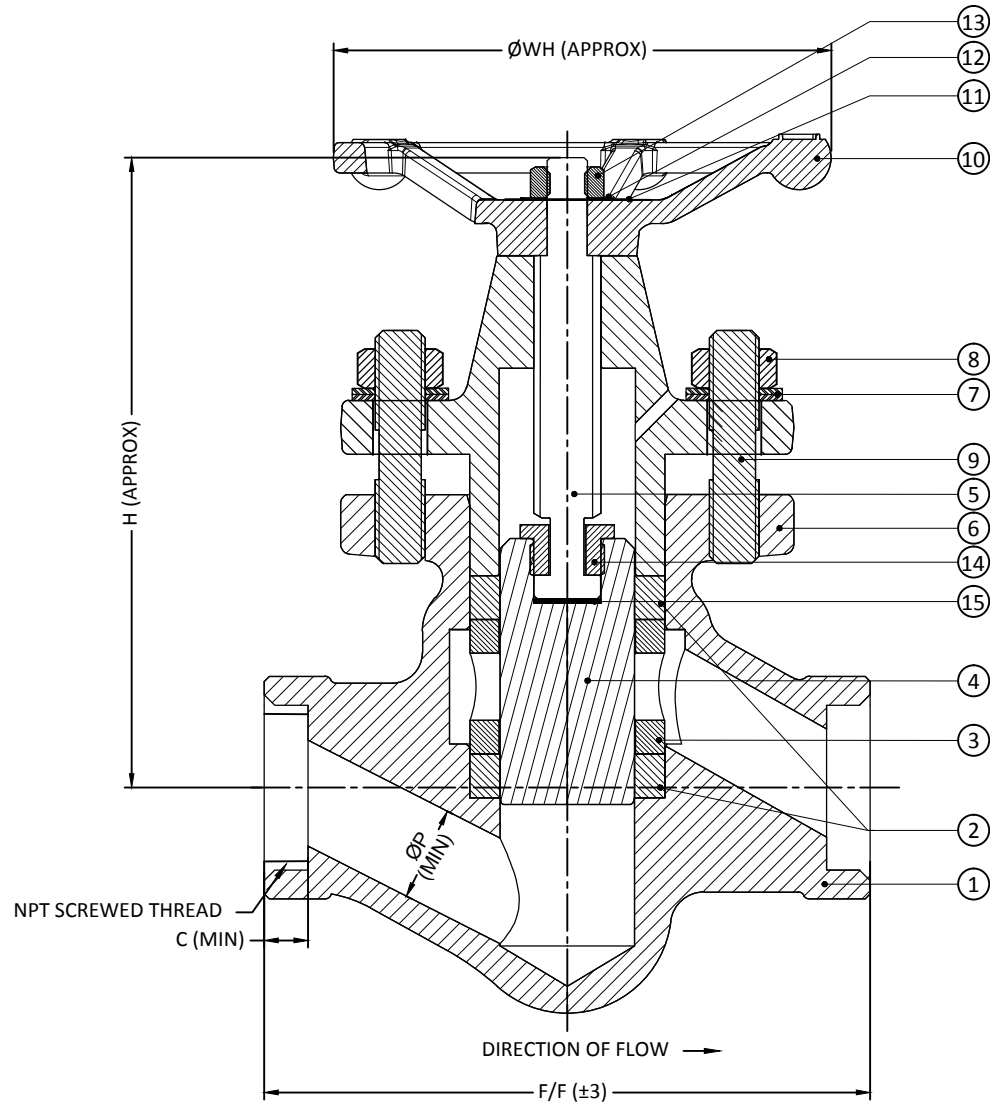

- DESIGN STANDARD :- API 602.
- TESTING STANDARD :- API 598.
- FACE TO FACE STANDARD :- MANUFACTURER'S STANDARD.
- SCREWED END STANDARD :- ASME B1.20.1

HYDRO TEST PRESSURE		
SHELL/BODY	211 kg / cm ²	15 SEC.
PNEUMATIC TEST PRESSURE		
LEAK TEST	7 kg / cm ²	15 SEC.

- To be used for client approval / remarks where applicable.

NO.	DESCRIPTION	MATERIAL	QTY.
15	SPLIT NUT WASHER	BRASS	1
14	SPLIT NUT	BRASS IS319 GR.1	1
13	STEM NUT	ASTM A 194 GR. 2H	1
12	HANDWHEEL WASHER	MS	1
11	NAME PLATE	STAINLESS STEEL	1
10	HAND WHEEL	MI / SGIRON	1
9	STUD	ASTM A 193 GR. B7	4
8	NUT	ASTM A 194 GR. 2H	4
7	BELLEVILLE WASHER	50CR V4/ASTM240 Gr.302	8
6	BONNET	ASTM A 105	1
5	SPINDLE	ASTM A 276 TYPE SS 410	1
4	PISTON	ASTM A 276 TYPE SS 410	1
3	LANTERN BUSH	ASTM A 276 TYPE SS 410	1
2	SEALING RING	GRAPHITE WITH SS304 REINFORCED	2
1	BODY	ASTM A 105	1

NO.	DESCRIPTION	MATERIAL	QTY.
All dimensions are in mm			APP. DATE
Scale :- Not to scale			MITTAL 07-11-19
TITLE :- PISTON VALVE - 800# - A105 - NPT		CHK. DATE	NIKUL 07-11-19
DRG. NO. :- GMV-PV-08		DRN. DATE	BHAVIN 07-11-19

C				PROJECT :-
B				CUSTOMER :- CUSTOMIZED STEAM SOLUTIONS PVT LTD
A				INQUIRY NO. :-
REV.	DESCRIPTION	DATE	APP. BY	P.O.NO. :-
				DATE :-

G M VALVE PVT. LTD. (RAJKOT)

SIZES	F/F	ØP	C	H
15 mm	73	9.5	14	53
20 mm	80	12.7	16	56
25 mm	100	17.5	20	66
32 mm	145	23.8	20	86
40 mm	145	28.6	24	86
50 mm	160	36.5	26	104

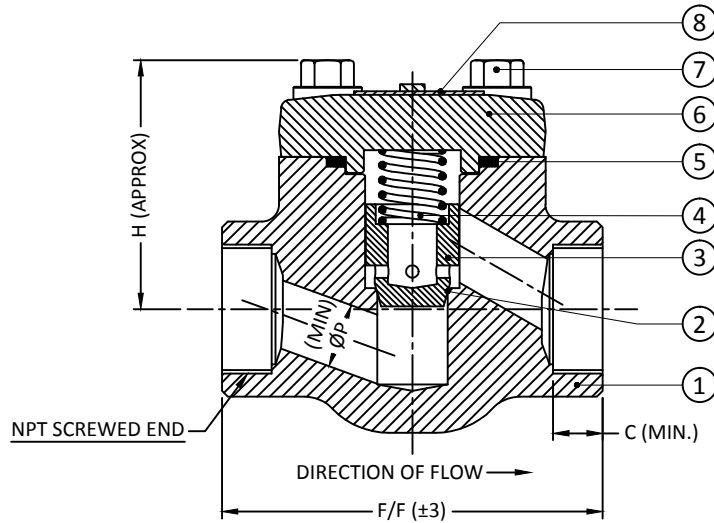

- DESIGN STANDARD :- ISO 15761.
- TESTING STANDARD :- API 598.
- FACE TO FACE STANDARD :- MANUFACTURER'S STANDARD.
- SCREWED END STANDARD :- ASME B1.20.1.

HYDRO TEST PRESSURE

SHELL/BODY	211 kg / cm ²	15 SEC.
SEAT	153 kg / cm ²	15 SEC.

- To be used for client approval / remarks where applicable.

8	NAME PLATE	STAINLESS STEEL	1
7	HEX BOLT	ASTM A 193 GR. B7	4
6	CHECK PLATE	ASTM A 105	1
5	GASKET	SS-316 SPIRAL WOUNDED+GRAPHITE	1
4	SPRING	ASTM A 313 SS-304	1
3	PLUG	ASTM A 276 TYPE SS-410	1
2	SEAT RING	13% CR. INTEGRAL	-
1	BODY	ASTM A 105	1

NO.	DESCRIPTION	MATERIAL	QTY.
All dimensions are in mm			APP. DATE
Scale :- Not to scale			07-11-19
TITLE :- CHECK VALVE - 800# - A105 - NPT		CHK. DATE	07-11-19
DRG. NO. :- GMV-CHV-09		DRN. DATE	07-11-19

C				PROJECT :-	
B				CUSTOMER :- CUSTOMIZED STEAM SOLUTIONS PVT LTD	
A				INQUIRY NO. :-	
REV.	DESCRIPTION	DATE	APP. BY	P.O.NO. :-	DATE :-



G M VALVE PVT. LTD. (RAJKOT)

SIZES	F/F	ØP	C	H
15 mm	73	9.5	14	53
20 mm	80	12.7	16	56
25 mm	100	17.5	20	66
32 mm	145	23.8	20	86
40 mm	145	28.6	24	86
50 mm	160	36.5	26	104

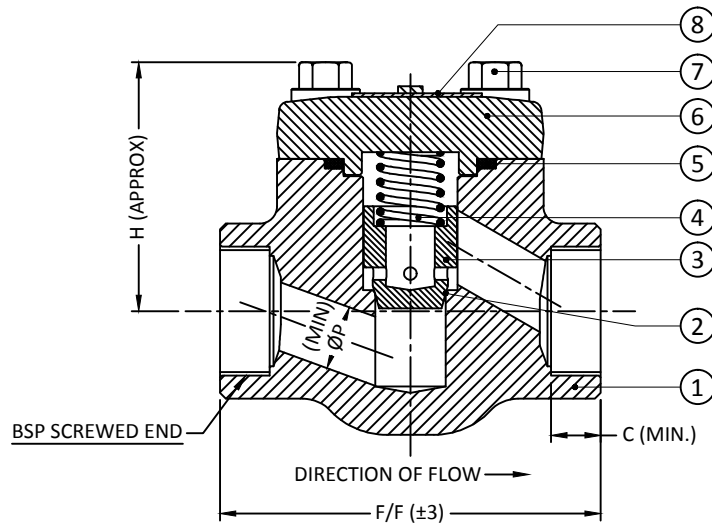

- DESIGN STANDARD :- ISO 15761.
- TESTING STANDARD :- API 598.
- FACE TO FACE STANDARD :- MANUFACTURER'S STANDARD.
- SCREWED END STANDARD :- ASME B1.20.1.

HYDRO TEST PRESSURE

SHELL/BODY	211 kg / cm ²	15 SEC.
SEAT	153 kg / cm ²	15 SEC.

- To be used for client approval / remarks where applicable.

8	NAME PLATE	STAINLESS STEEL	1
7	HEX BOLT	ASTM A 193 GR. B7	4
6	CHECK PLATE	ASTM A 105	1
5	GASKET	SS-316 SPIRAL WOUNDED+GRAPHITE	1
4	SPRING	ASTM A 313 SS-304	1
3	PLUG	ASTM A 276 TYPE SS-410	1
2	SEAT RING	13% CR. INTEGRAL	-
1	BODY	ASTM A 105	1

NO.	DESCRIPTION	MATERIAL	QTY.
All dimensions are in mm			APP. DATE
Scale :- Not to scale			MITTAL
TITLE :- CHECK VALVE - 800# - A105 - BSP		CHK. DATE	07-11-19
DRG. NO. :- GMV-CHV-10		DRN. DATE	07-11-19
			BHAVIN

C				PROJECT :-	
B				CUSTOMER :- CUSTOMIZED STEAM SOLUTIONS PVT LTD	
A				INQUIRY NO. :-	
REV.	DESCRIPTION	DATE	APP. BY	P.O.NO. :-	DATE :-



G M VALVE PVT. LTD. (RAJKOT)

SIZES	F/F	ØP	C	H
15 mm	73	9.5	14	53
20 mm	80	12.7	15	56
25 mm	100	17.5	19	66
32 mm	120	23.8	19	86
40 mm	120	28.6	19	86
50 mm	130	36.5	20	104

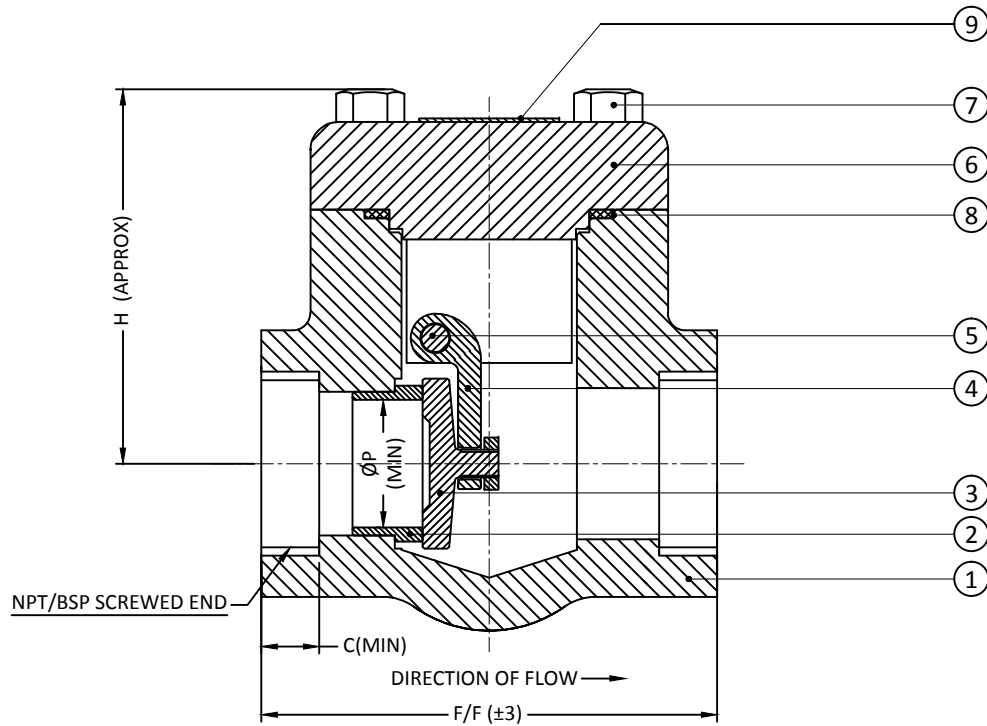

- DESIGN STANDARD :- ISO 15761.
- TESTING STANDARD :- API 598.
- FACE TO FACE STANDARD :- MANUFACTURING STANDARD
- SCREWED END STANDARD :- ASME B 1.20.1.

HYDRO TEST PRESSURE

SHELL/BODY	211 kg / cm ²	15 SEC.
SEAT	153 kg / cm ²	15 SEC.

NO.	DESCRIPTION	MATERIAL	QTY.
9	NAME PLATE	SS	1
8	GASKET	SS 316 SPW + GRAPHITE	1
7	HEX BOLT	ASTM A 193 GR. B7	4
6	BONNET	ASTM A 105	1
5	HINGE PIN	ASTM A 276 TYPE SS 316	1
4	HINGE	ASTM A 351 GR. CF8M	1
3	DISC	ASTM A 276 TYPE SS 410	1
2	SEAT RING	ASTM A 276 TYPE SS 410	1
1	BODY	ASTM A 105	1

All dimensions are in mm			APP. DATE	MITTAL
Scale :- Not to scale			CHK. DATE	07-11-19
TITLE :- SWING CHECK VALVE - 800# - A105 - NPT/BSP			DRN. DATE	NIKUL
DRG. NO. :- GMV-SCHV-11			DATE	07-11-19

C				PROJECT :-
B				CUSTOMER :- CUSTOMIZED STEAM SOLUTIONS PVT LTD
A				INQUIRY NO. :-
REV.	DESCRIPTION	DATE	APP. BY	P.O.NO. :-
				DATE :-

G M VALVE PVT. LTD. (RAJKOT)